









|   |   |   |   |
|---|---|---|---|
| <p><b>A</b></p>  <p>3. 5X45mm<br/>8+1pcs</p> | <p><b>B</b></p>  <p>3. 5X25mm<br/>4+1pcs (black)</p> | <p><b>C</b></p>  <p>Left disc 2pcs</p> | <p><b>D</b></p>  <p>Rotary disc 2pcs</p> |
| <p><b>1</b></p>  <p>1pc</p>                  | <p><b>2</b></p>  <p>1pc</p>                          |   |   |
| <p><b>3</b></p>  <p>1pc</p>                  | <p><b>4</b></p>  <p>1pc</p>                          |   |   |
| <p><b>5</b></p>  <p>1pc</p>                 | <p><b>6</b></p>  <p>1pc</p>                         |   |   |
| <p><b>7</b></p>  <p>∅ 10 2pcs</p>          | <p><b>8</b></p>  <p>∅ 12 2pcs</p>                  |   |   |

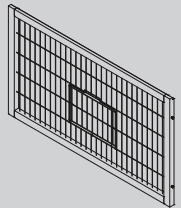
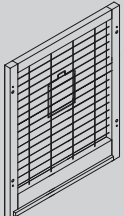
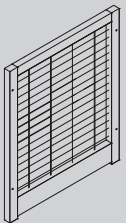
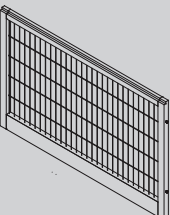
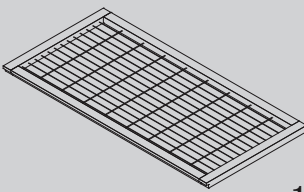
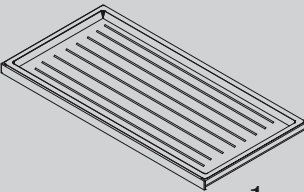

(DE) Bitte beachten Sie, dass eventuell durchlaufende Flüssigkeiten wie Wasser oder Urin den Fußboden beschädigen könnten. Der ideale Untergrund sind Stein-, fliesen- oder Kunststoffböden.

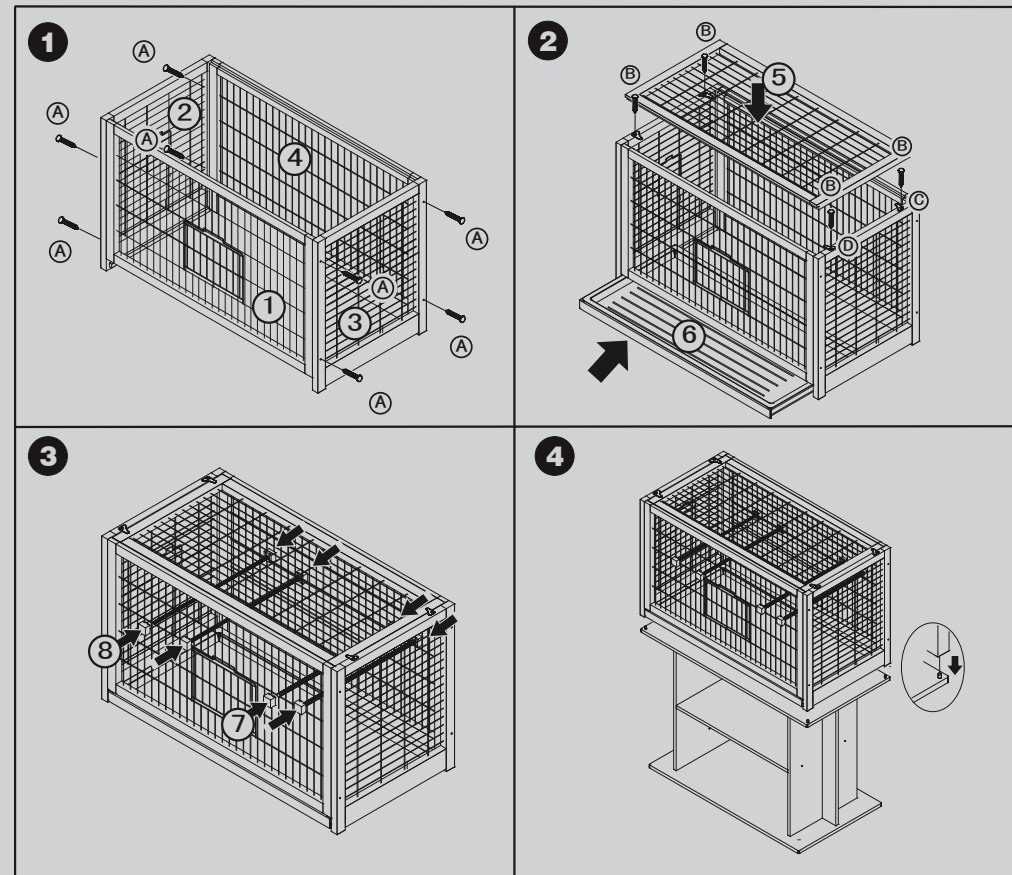
(FR) Veuillez prendre en compte le fait que les fuites de liquides comme l'eau ou l'urine peuvent endommager le fond. Les sols en pierre, carrelage ou plastique constituent les meilleurs fonds.

(EN) Please take into account that any liquids that leak out such as water or urine may damage your floors. An ideal base would be stone, tile or synthetic floors.

(IT) Tenere presente che eventuali liquidi come acqua o urina possono danneggiare il pavimento. Il fondo ideale è composto da pietre, piastrelle o plastica.